

HFE-MULTI and HFE-MULTI AL

Combined Standard and Self Test Emergency inverters

Suitable for all linear and compact lamps, 1 h or 3 h duration.

DESCRIPTION

Emergency lighting module to be used with Standard or Self testing facility. Operating from NiCd or NiMh batteries, 1 hour and 3 hour duration.

HFE-MULTI and HFE-MULTI AL incorporate five pole technology for use with HF and Magnetic ballasts, providing preheat starting and permanent cathode heating during the emergency operation. Self testing is conducted on a monthly functional test and annual duration test.

HFE-MULTI/ AL is designed for use in self-contained systems where they are housed within the luminaires.

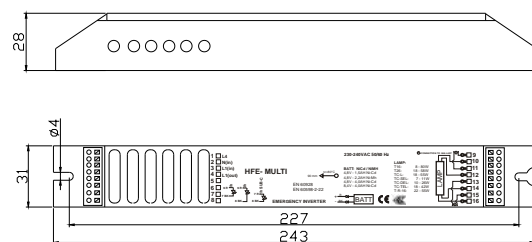

MODULE

- For use with HF ballasts and Magnetic ballasts
- NiCd or NiMh battery options
- Operation mode set by connection of LED
- Deep discharge battery protection
- Quick release battery coupling
- Self testing programs inside, according with EN 50172 (pr-IEC 62034)
- Easy programmable 1 h or 3 h duration
- During emergency testing the module is disconnected from the mains-supply
- 5 pole technology
- AC output to lamp
- Cathode heating
- Pre heat starting
- Ta range 0-55°C
- Size (28 mm x 31 mm x 243 mm)

LAMP TYPES:
T5, T8, TC-S/E, TC-L, TC-DD/E, TC-TE, T-R-16
Emergency light output, see table

BATTERY:
NiCd D-cells, NiCd Cs-cells, NiMh Cs-cells
High temperature cells
Battery information, see table

In accordance with:

- EN 60598-2-22
- EN 61347
- EN 61347-2-7:2001
- EN 61347-1:2001
- EN 50172
- EN 55015:2000 + addendum 2
- IEC 61347-2-7
- IEC 61347-1

Emergency Module

Article number:	Article text:
36401	HFE-MULTI 230-240V 50/60Hz
36405	HFE-MULTI 230-240V 50/60Hz with potential free alarmcontact
36410	HFE-MULTI 115-127V 50/60Hz
36411	HFE-MULTI 115-127V 50/60Hz with potential free alarmcontact

LED Indicator

Article number:	Article text:
92025	DS1-ST LED INDICATOR SELF TEST
92026	D1-S LED INDICATOR STD

Battery Packs

Article number:	Voltage:	Capacity:	Cell:	Type:	Configuration:
530015	4.8V	4.0Ah	D cell	Ni-Cd	Stick/AMP plug
530003	8.4V	4.0Ah	D cell	Ni-Cd	Stick/AMP plug
530017	4.8V	1.5Ah	Cs cell	Ni-Cd	Stick/AMP plug
530021	4.8V	2.2Ah	Cs cell	Ni-Mh	Stick/AMP plug

STANDARD – configuration HFE-MULTI

By connecting the Barel D1-S LED INDICATOR art no 92026
HFE-MULTI will operate as a Standard Emergency module.
Testing will be done manually by disconnection of the mains to the module.

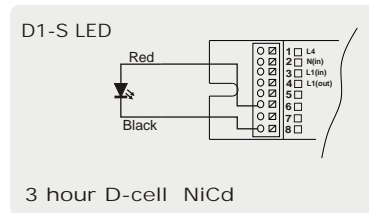
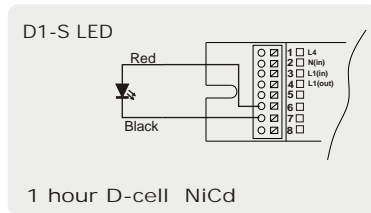
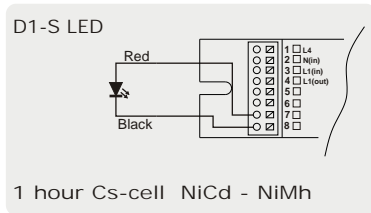

Mechanical details LED D1-S



- LED
- Green
 - Mounting hole 6,2mm
 - Lead length 1050mm

SELF TEST – configuration HFE-MULTI and HFE MULTI AL

By connecting the Barel DS1-ST LED INDICATOR art no 92025,
HFE-MULTI and HFE-MULTI AL will operate as a self testing Emergency module.
The HFE-MULTI and HFE-MULTI AL will automatically test the battery, lamp and charger in accordance with EN-50172. (pr-IEC 62034). Within 48 hours after the mains is connected, a function test will start.

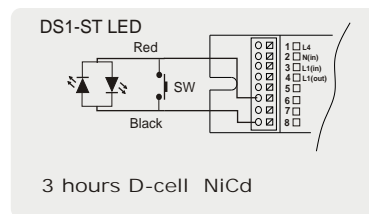
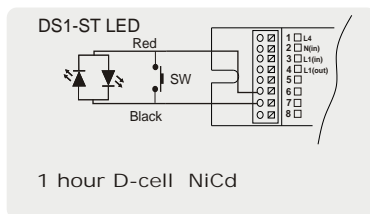
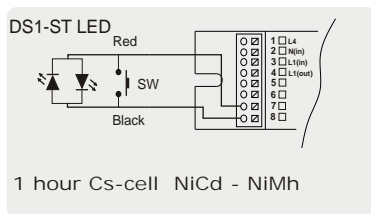

Mechanical details Bi-colour LED and switch DS1-S



- LED
- Green/red
 - Mounting hole 6,2mm
 - Lead length 55mm

- Test switch
- Mounting hole 4,8 mm
 - Lead length 1050 mm

SELF TEST - CONFIGURATION with internal relay HFE MULTI AL Alarm output

HFE-MULTI AL has potential free contacts for monitoring the emergency module. After each internal or manual test cycles, the module will indicate the results on local LED indicator and output contacts:

NC = NORMALLY CLOSE

Emergency module OK: contact will be close,
Emergency module FAULT: contact will open.

The HFE-MULTI AL will automatically test the battery, lamp and charger in accordance with EN-50172. Within 48 hours after the mains is connected, the HFE-MULTI AL will start an function test. If any failure occurs, this will activate the monitoring outputs, together with the LED indicator.

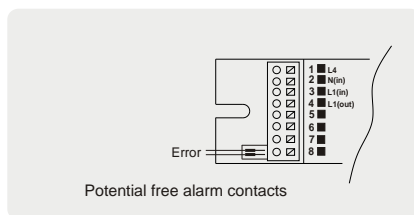

Testing

Test sequences performed in Self Test mode:
Months 1 to 11: HFE-MULTI and HFE-MULTI AL testing the charger and the lamp functions for 5 minutes.

Month 12: HFE-MULTI and HFE-MULTI AL carrying out full discharge of the battery for the whole period, 1 or 3 hours.

Manual test: press the SW, a test of the charger and lamp functions will start, the test runs for approx. 8 seconds.

Test results are presented at LED indicator

Electrical connections

Cross section from 0,5mm² to 1,5mm²

Strip length from 8,5 mm

Strip length to 9,5 mm

Push button

Front entry

More information WAGO data sheet 250-208

Status LED indicator (all modes)

LED	Status
Green	System OK
Red	Charging fault
Flashing red with interval	Lamp fault
Flashing red continous	Battery fault

Emergency Light Output

Lamp type		1 hours duration			3 hours duration	
		Battery 4,8V-1,5Ah NiCd Cs-cell	Battery 4,8V- 2,2Ah NiMh Cs-cell	Battery 4,8V- 4,0Ah NiCd D-cell	Battery 4,8V- 4,0Ah NiCd D-cell	Battery 8,4V- 4,0Ah NiCd D-cell
		Light output	Light output	Light output	Light output	Light output
TC-S/E	7W	43 %	43 %	52 %	43 %	77 %
	9W	27 %	27 %	32 %	27 %	63 %
	11W	21 %	21 %	30 %	21 %	55 %
TC-D/E	10W	27 %	27 %	35 %	27 %	57 %
	13W	21 %	21 %	32 %	21 %	46 %
	18W	18 %	18 %	30 %	18 %	34 %
	26W	15 %	15 %	26 %	15 %	24 %
T5	8W	40 %	40 %	51 %	40 %	63 %
	14W	24 %	24 %	44 %	24 %	39 %
	21W	15 %	15 %	29 %	15 %	30 %
	24W	13 %	13 %	27 %	13 %	23 %
	28W	10 %	10 %	24 %		23 %
	35W			20 %		18 %
	39W			17 %		15 %
	49W			14 %		13 %
	54W			13 %		11 %
	80W			8 %		7 %
T8	15W	22 %	22 %	49 %	22 %	39 %
	18W	18 %	18 %	40 %	18 %	34 %
	36W	7 %	7 %	16 %	7 %	19 %
	58W			12 %		11 %
TC-L	18W	18 %	18 %	30 %	18 %	33 %
	24W	13 %	13 %	25 %	13 %	26 %
	36W	8 %	8 %	19 %	8 %	18 %
	40W			15 %		17 %
	55W			11 %		12 %
TC-DD/E	16W	24 %	24 %	40 %	24 %	39 %
	28W	16 %	16 %	21 %	16 %	23 %
	38W	8 %	8 %	16 %	8 %	17 %
	55W	9 %	9 %	15 %	7 %	12 %
TC-TE	18W	17 %	17 %	21 %	17 %	33 %
	26W	13 %	13 %	17 %	13 %	24 %
	32W	7 %	7 %	12 %	7 %	21 %
	42W			9 %	6 %	16 %
T-R-16	22W	15 %	15 %	25 %	15 %	27 %
	40W	7 %	7 %	14 %	7 %	15 %
	55W	5 %	5 %	11 %	6 %	11 %

Barel recommend the use of 8,4V 4Ah battery when operating High Output lamps.

Battery Packs

It is recommended to only use High Temperature Cs-cell or D-cell batteries for Emergency Lighting applications. Both NiCd and NiMh battery packs can be used with the HFE MULTI and HFE-MULTI AL. Battery Packages can be supplied in various formats to suit all applications.

The cells are designed to operate at High ambient Temperatures.

NiCd D cells	Article number	Configuration	Figure	Conduction mm	L mm	A mm	B mm	C mm	Weight g
NiCd D 4,8V 4Ah	530015	Slick	1	210 (1)	285	263	29	36	540 (1)
NiCd D 8,4V 4Ah	530003	Slick	1	210 (1)	464	443	29	36	945 (1)

NiCd Cs cells	Article number	Configuration	Figure	Conduction mm	L mm	A mm	B mm	C mm	Weight g
NiCd 4,8V 1,5Ah	530017	Slick	2	113 (1)	210	190	19	27	210 (1)

NiMh Cs cell	Article number	Configuration	Figure	Conduction mm	L mm	A mm	B mm	C mm	Weight g
NiMh Cs cells 4,8V 2,2Ah	530021	Slick	2	113 (1)	210	190	19	27	210 (1)

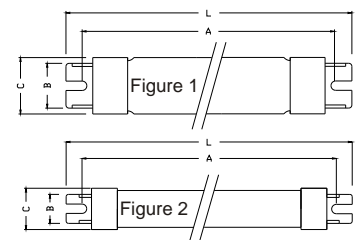

(1) For reference only

HFE-MULTI Emergency Module wiring diagrams

1) Wiring diagram for twin lamp with HF ballast
L1 switched line
L4 unswitched line

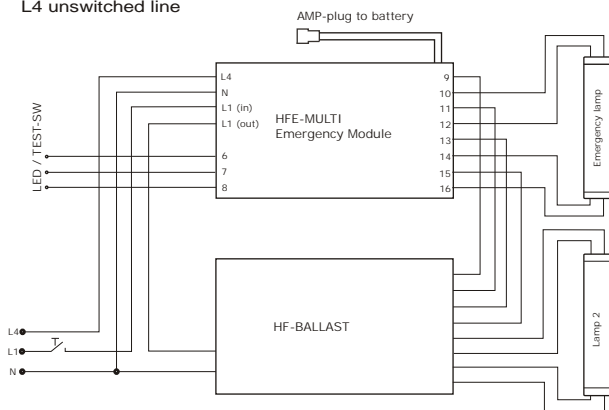

4) Wiring diagram for twin lamp with conventional ballast
L1 switched line
L4 unswitched line

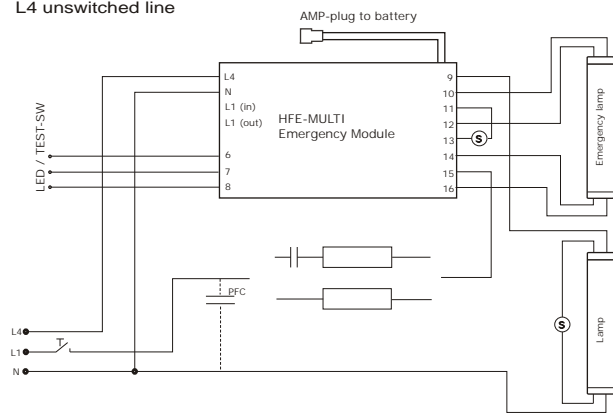

2) Wiring diagram for single lamp with HF ballast
L1 switched line
L4 unswitched line

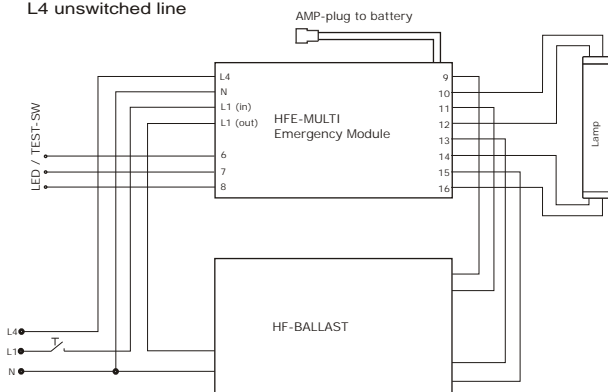

5) Wiring diagram for single lamp with conventional ballast
L1 switched line
L4 unswitched line

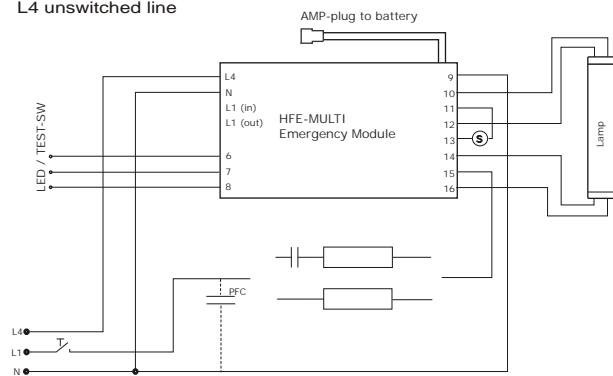

3) Wiring diagram for non maintained operation
L1 switched line
L4 unswitched line

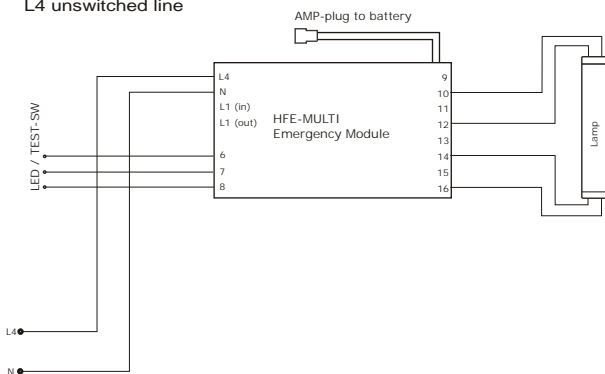

Wiring diagram for others ballast, contact the factory

HFE-MULTI AL Emergency Module wiring diagrams

1) Wiring diagram for twin lamp with HF ballast
L1 switched line
L4 unswitched line

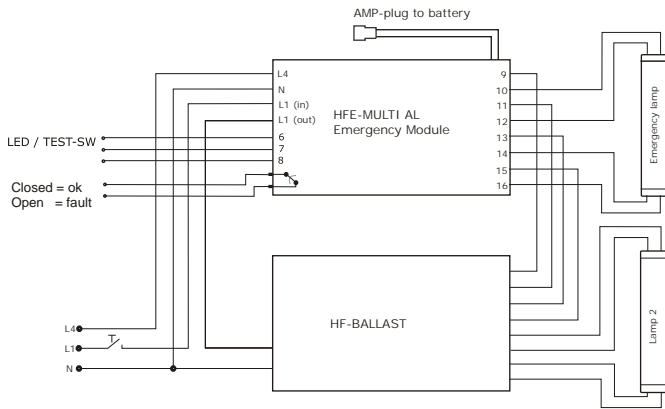

4) Wiring diagram for twin lamp with conventional ballast
L1 switched line
L4 unswitched line

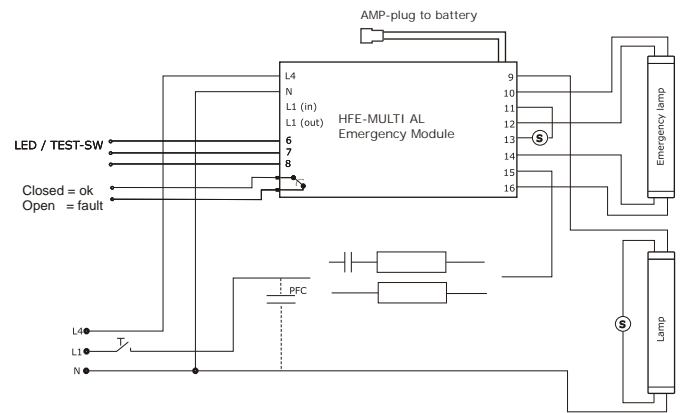

2) Wiring diagram for single lamp with HF ballast
L1 switched line
L4 unswitched line

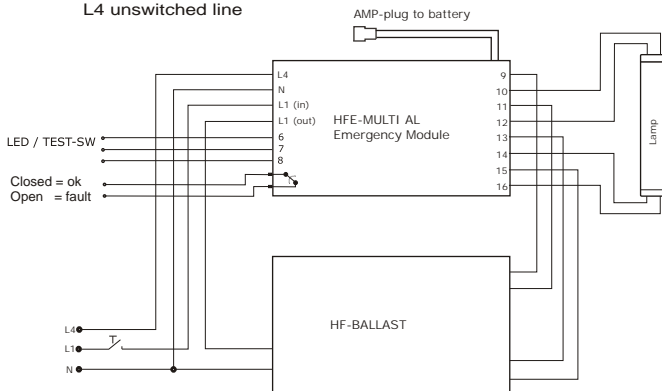

5) Wiring diagram for single lamp with conventional ballast
L1 switched line
L4 unswitched line

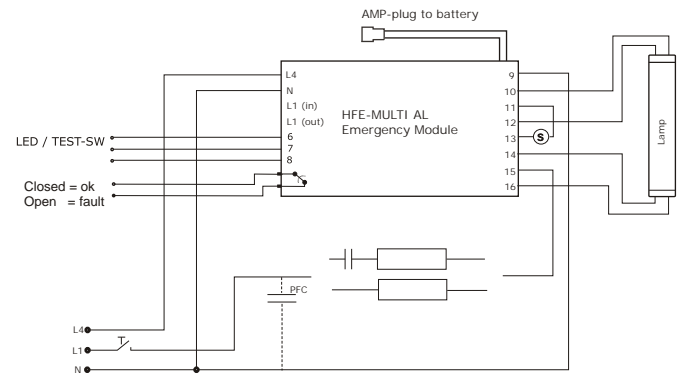

3) Wiring diagram for non maintained operation
L1 switched line
L4 unswitched line

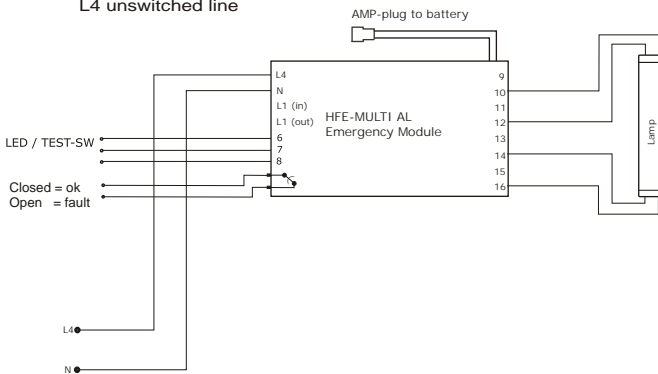

Wiring diagram for others ballast, contact the factory